

5. Install the OCV(Oil Control Valve) filter(A).

Tightening torque :

40.2 ~ 50.0N.m (4.1 ~ 5.1kgf.m, 29.7 ~ 36.9lb-ft)

■ 1.6 CVVT

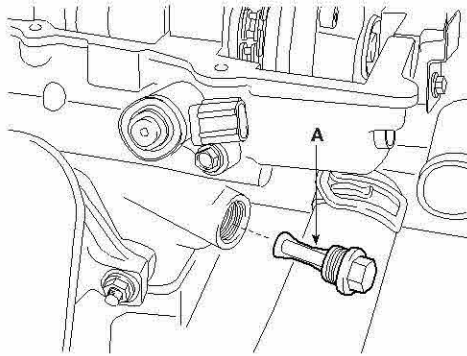

ACJF117A

NOTE

- Always use a new OCV(Oil Control Valve) filter gasket.
- Keep clean the OCV(Oil Control Valve) filter.

6. Install the OCV(Oil Control Valve)(A).

Tightening torque :

9.8 ~ 11.8N.m (1.0 ~ 1.2kgf.m, 7.2 ~ 8.7lb-ft)

■ 1.6 CVVT

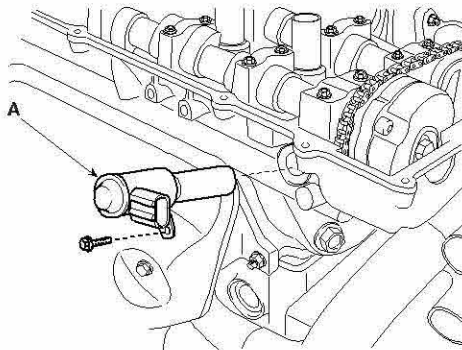

ACJF118A

CAUTION

- Do not reuse the OCV(Oil Control Valve) when dropped.
- Keep clean the OCV(Oil Control Valve).
- Do not hold the OCV(Oil Control Valve) sleeve during servicing.
- When the OCV(Oil Control Valve) is installed on the engine, do not move the engine with holding the OCV(Oil Control Valve) yoke.

7. Install the camshafts.

- 1) Align the camshaft timing chain with the intake timing chain sprocket and exhaust timing chain sprocket as shown.

■ 1.6 CVVT

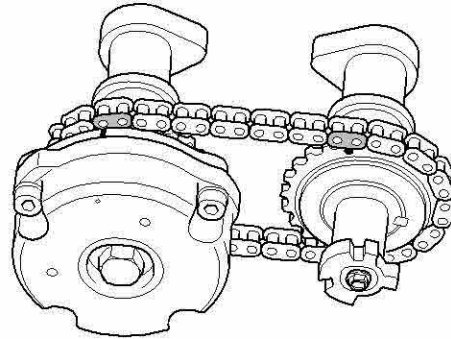

ACJF094A

- 2) Install the camshaft(A) and bearing caps(B).

Tightening torque :

11.8 ~ 13.7N.m (1.2 ~ 1.4kgf.m, 8.7 ~ 10.1lb-ft)

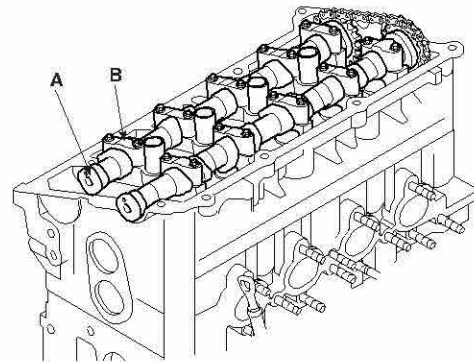

EDKD124A

3) Install the timing chain auto tensioner(A).

Tightening torque :

7.8 ~ 9.8N.m (0.8 ~ 1.0kgf.m, 5.8 ~ 7.2lb-ft)

■ 1.6 CVVT

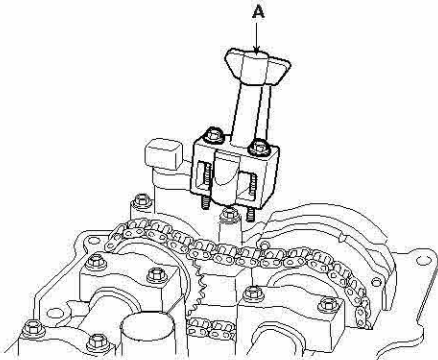

ACJF119A

8. Using the SST (09221 - 21000), install the camshaft bearing oil seal.

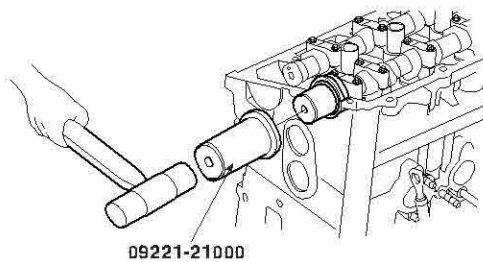

09221-21000

EDKD125A

9. Install the camshaft sprocket. (Refer to EM - 24)

10. Install the cylinder head cover.

1) Install the cylinder head cover gasket(A) in the groove of the cylinder head cover(B).

■ 1.6 CVVT

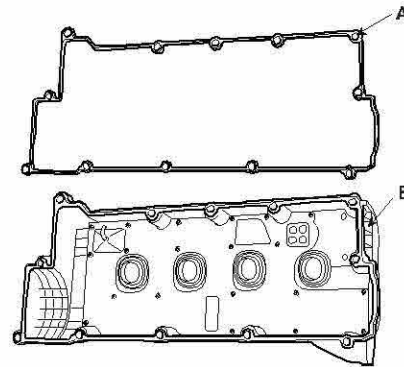

ACJF095A

NOTE

- Before installing the cylinder head cover gasket, thoroughly clean the cylinder head cover and the groove.
- When installing, make sure the cylinder head cover gasket is seated securely in the corners of the recesses with no gap.

2) Apply liquid gasket to the head cover gasket at the corners of the recess.

■ 1.6 CVVT

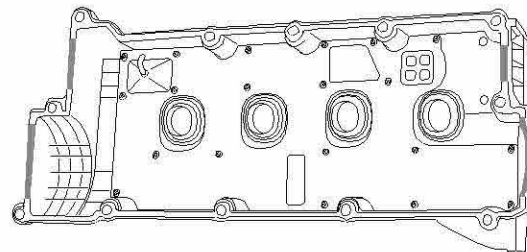

ACJF095A

NOTE

- Use liquid gasket, loctite No. 5999.
- Check that the mating surfaces are clean and dry before applying liquid gasket.
- After assembly, wait at least 30 minutes before filling the engine with oil.